



PX SERIES FUEL CELL HUMIDIFIERS

FOR LOW PRESSURE SYSTEMS

PRODUCT DESCRIPTION

The Px Series is a planar membrane humidifier designed for low-pressure, low-temperature applications requiring high transfer efficiency. It is a fully passive device – with no moving parts and requiring no external power supply – and can be operated in either gas-to-gas or liquid-to-gas mode.

ADVANTAGES

- For lower pressure 1 to 10kW systems
- Counter-flow Plate Design
- Stand-alone membrane cartridges available
- Low cost, high-volume manufacturing
- Low pressure drop
- Liquid-to-gas operation possible



1455 East Georgia St.
Vancouver, BC, V5L 2A9,
Canada

+1 604 488 1132
sales@dpoint.ca
www.dpoint.ca

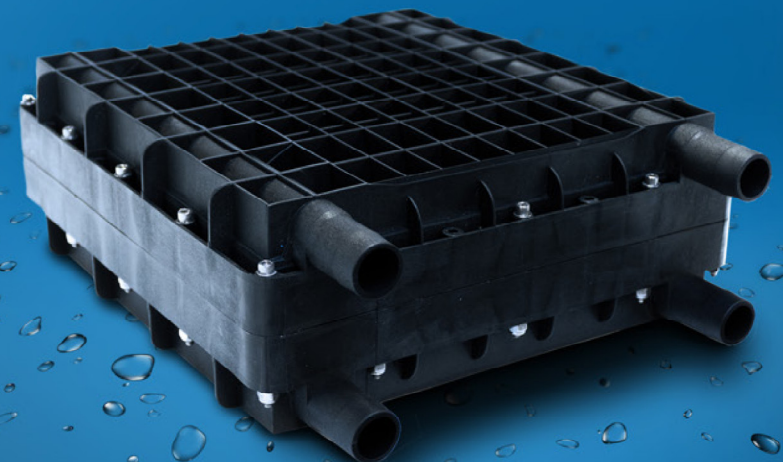



PX SERIES FUEL CELL HUMIDIFIERS

Parameter	Px1-32	Px1-114	Px4-268
Power Range	1 kW	3kW	3-10kW
Flow Range (sLPM)	10 - 60	50 - 200	100 - 600
Dew Point Approach Temperature Range (°C)*	2 - 6	5 - 12	5 - 12
Pressure Drop Range (kPa)	0.5 - 3.0	0.5 - 8.0	0.5 - 2.5
Pressure limit (kPa)	35 kPa,g	35 kPa,g	35 kPa,g
Temperature limit (°C)	70	70	70
Port Connection	16 mm	16 mm	25mm barb
Volume with housing (L)	0.8	2.0	10.5
Dimensions [L x W x H]	18 x 7 x 6 cm	18 x 16 x 7 cm	34 x 28 x 11 cm
Weight (kg)	0.3	0.7	3.8

* Dependent on operating conditions (contact us to run our performance model at your specific conditions)

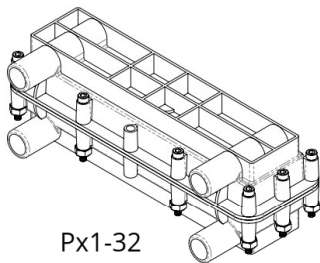

Px1-32

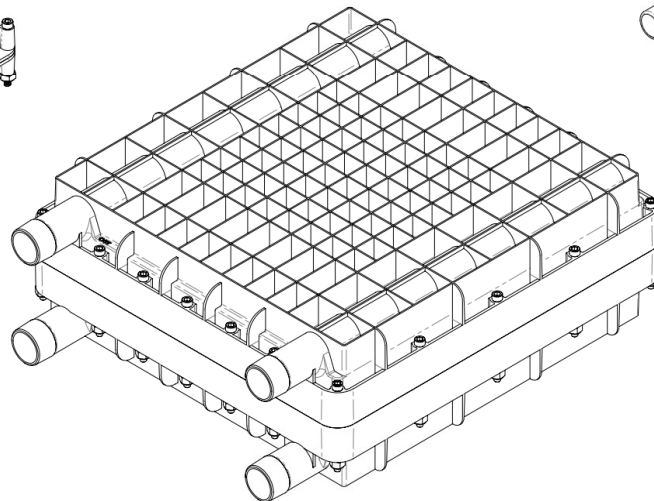

Px4-268

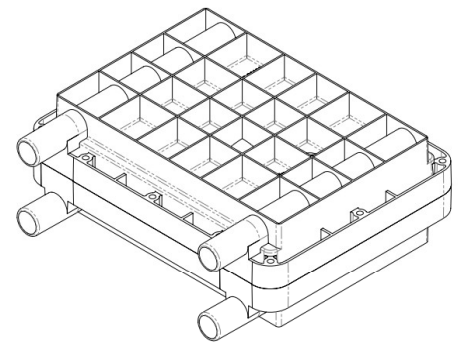

Px1-114

